



SCORE ON DOTTED LINES  
CUT SOLID LINES AND ALONG EDGE

THIS FOLDS INSIDE  
(NO TAPE)

TAB

TAB

INSERT THIS TAB INSIDE THE SLOT

CUT  
THIS  
OUT

EXPOSURE TIMES: (seconds)

4-8	12-20	30-3min

WIND FILM ONE FULL TURN  
AFTER EVERY SHOT

WANT ANOTHER?:  
[CORBIS.COM/READYMECH](http://CORBIS.COM/READYMECH)



CUT  
THIS  
OUT

TAB

TAB

THIS FOLDS INSIDE  
(NO TAPE)



THIS BLACK AREA  
GOES INSIDE THE BOX

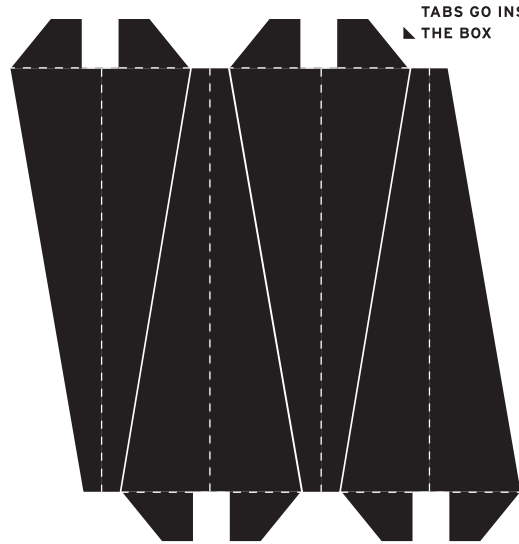

TABS GO INSIDE  
THE BOX

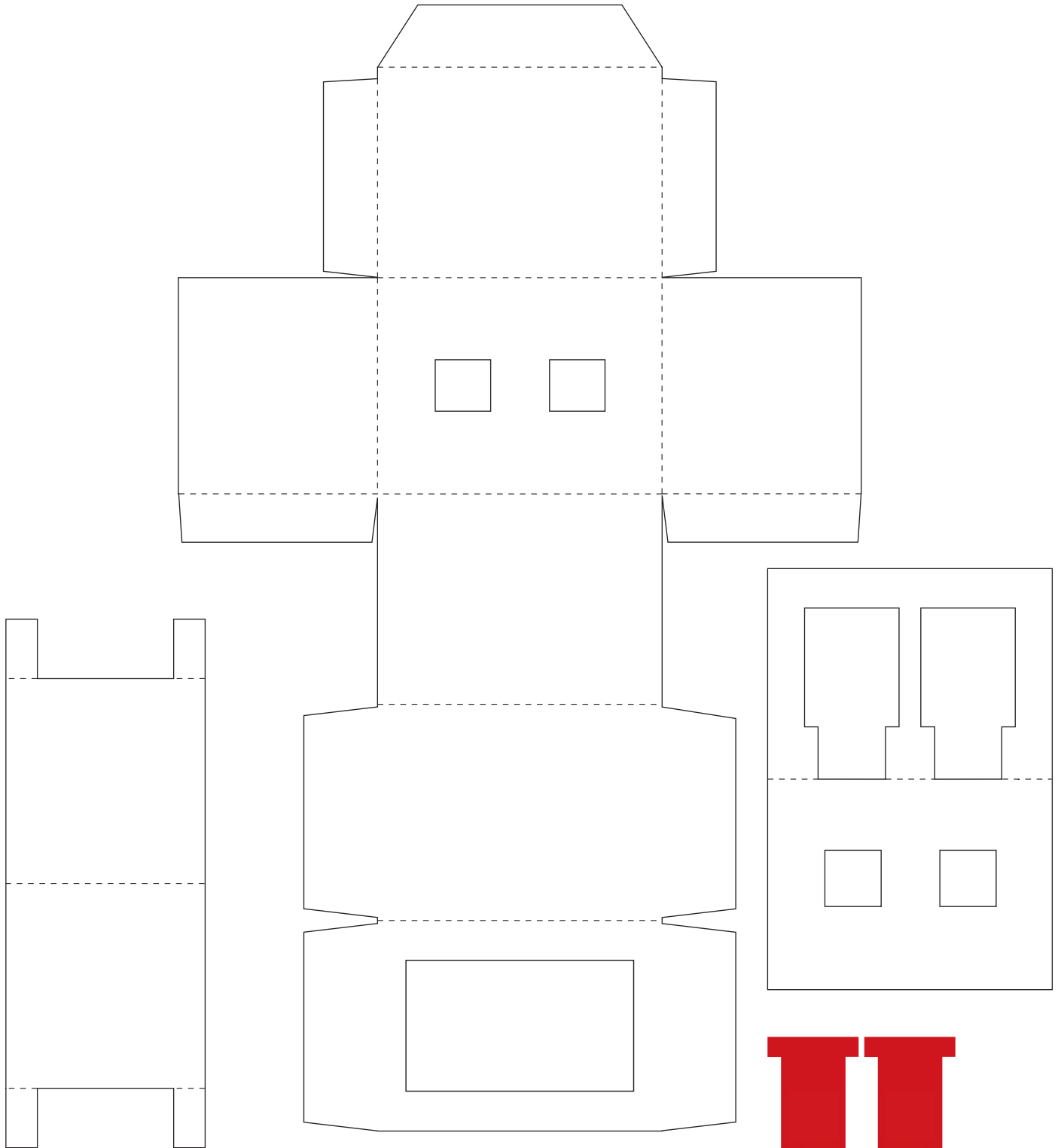

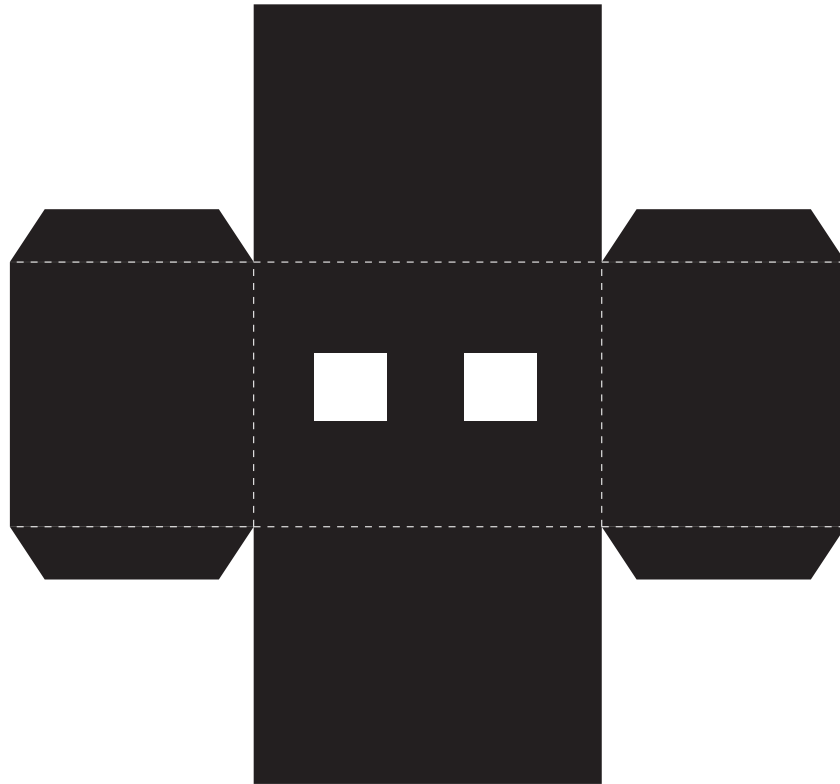

# INSTRUCTIONS

## BUILDING SUPPLIES

- Several sheets of good printer paper
- One regular cereal box for the light-safe interior
- A pen knife razor blade for cutting
- Some double-sided tape or glue
- Thin needle for making a pinhole
- Small piece of aluminum foil or soda can to puncture with the needle
- One new roll of film, preferably ISO200
- One film canister from which the film has been removed. You can empty a new roll, or get an empty canister from any photo developer

## TAKING PHOTOS

- The best photos are taken on a bright day
- Always wind the film one full rotation after every photo
- Use a paperclip to wind the film
- Remember to rewind the film before disassembling the unit for development
- Hold the camera very still when shooting
- Follow the chart for exposure times

## DEVELOPING PHOTOS

- Photos can be processed normally, like any other 35mm film
- If possible, ask your developer not to cut the prints
- If your prints are grey or foggy, you might have a light leak. Use some extra dark tape to seal up your camera interior, and give it another try

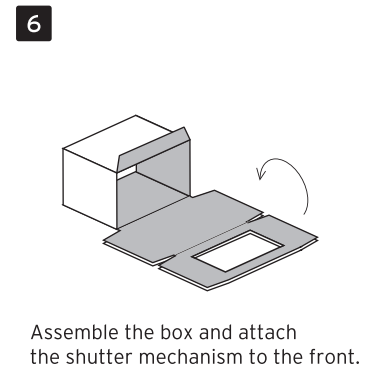
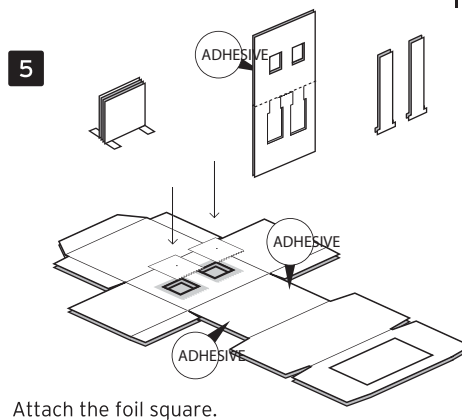
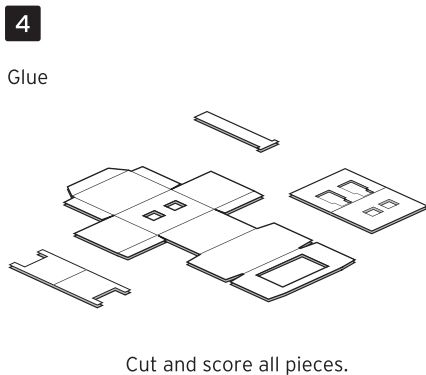
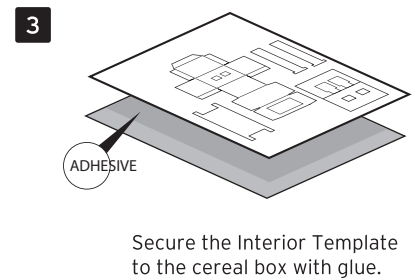
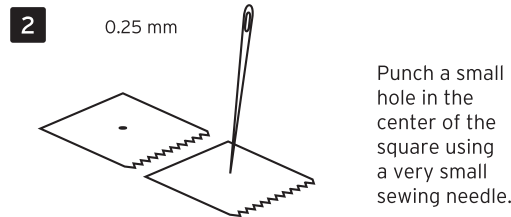
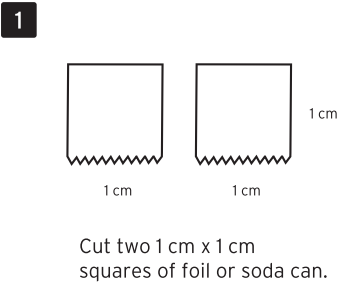



**7**

This is tricky. Pop open the empty film canister, and invert the spool so that there is a light-safe canister to receive exposed film. Be sure to include a long strip of tape around the spool for feeding the new film in.

**8**

Feed the film into the empty canister.

**9**

Lay the film onto the open box, and close the frame over the top.

**10**

Build the light tub for extra light protection. You never can be too careful.

**11**

Insert the light tub into the box, and add the light-splitter.



12

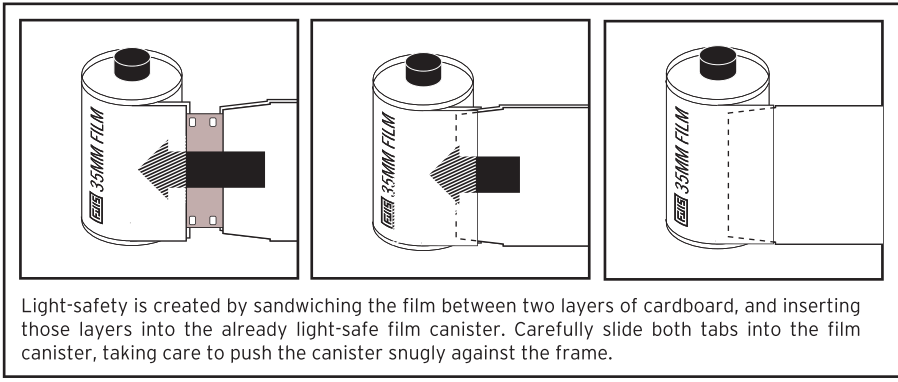

13

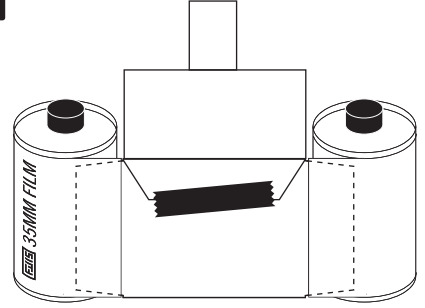

After sliding the cardboard tabs into the film canisters, wrap the top of the box over the back and tape it down. This should secure the entire box.

14

Build the camera exterior, and insert the film in through the back. Be sure to feed the shutter handle through the slot near the top of the camera.

